

Step 1: Remove bottom covering and take out couch back and toss pillow.

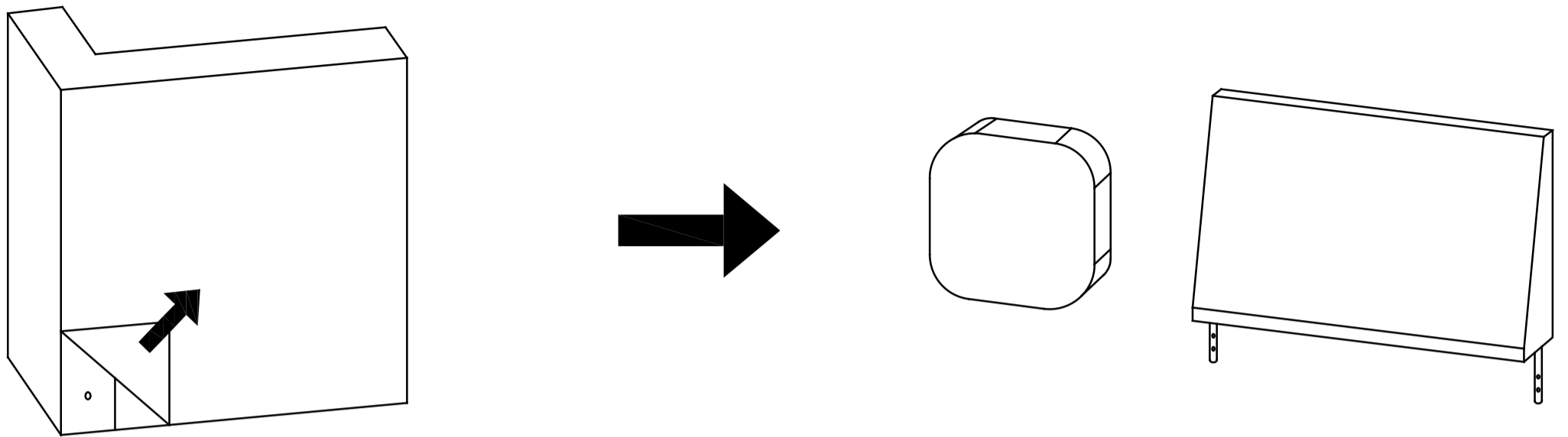

Step 2: Remove back covering and take out 5 legs, 5 hand bolts, and toss pillow and couch back.

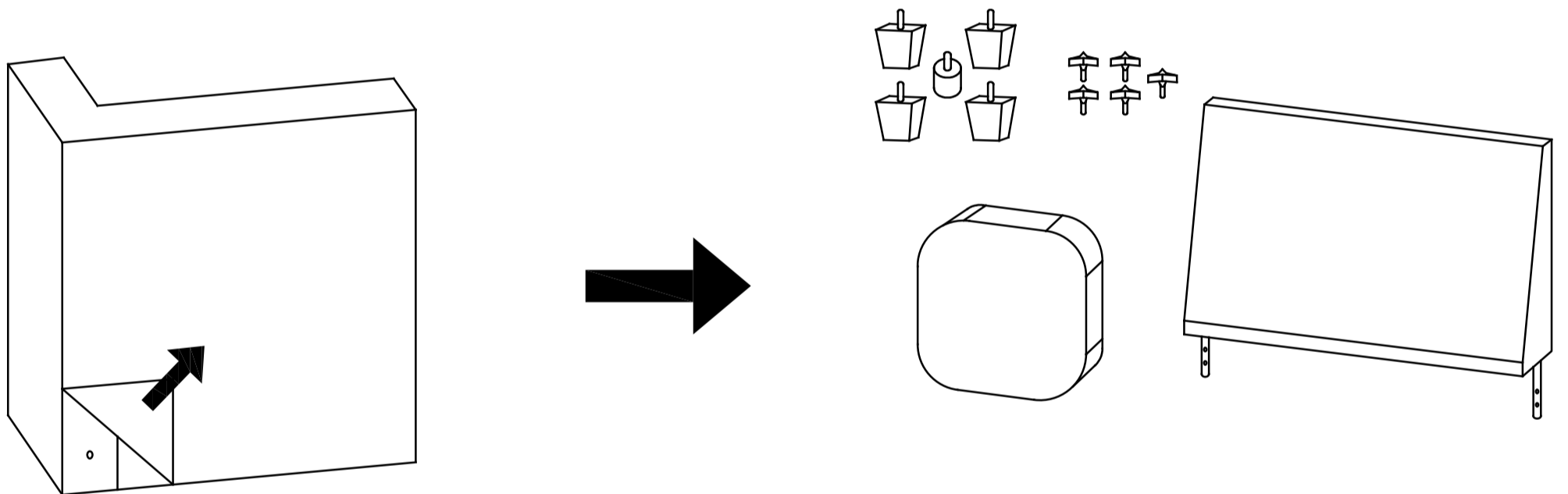

Step 3: Place backs on the sofa ends using the KD brackets. Be sure to match left back to left seat and right back to right seat.

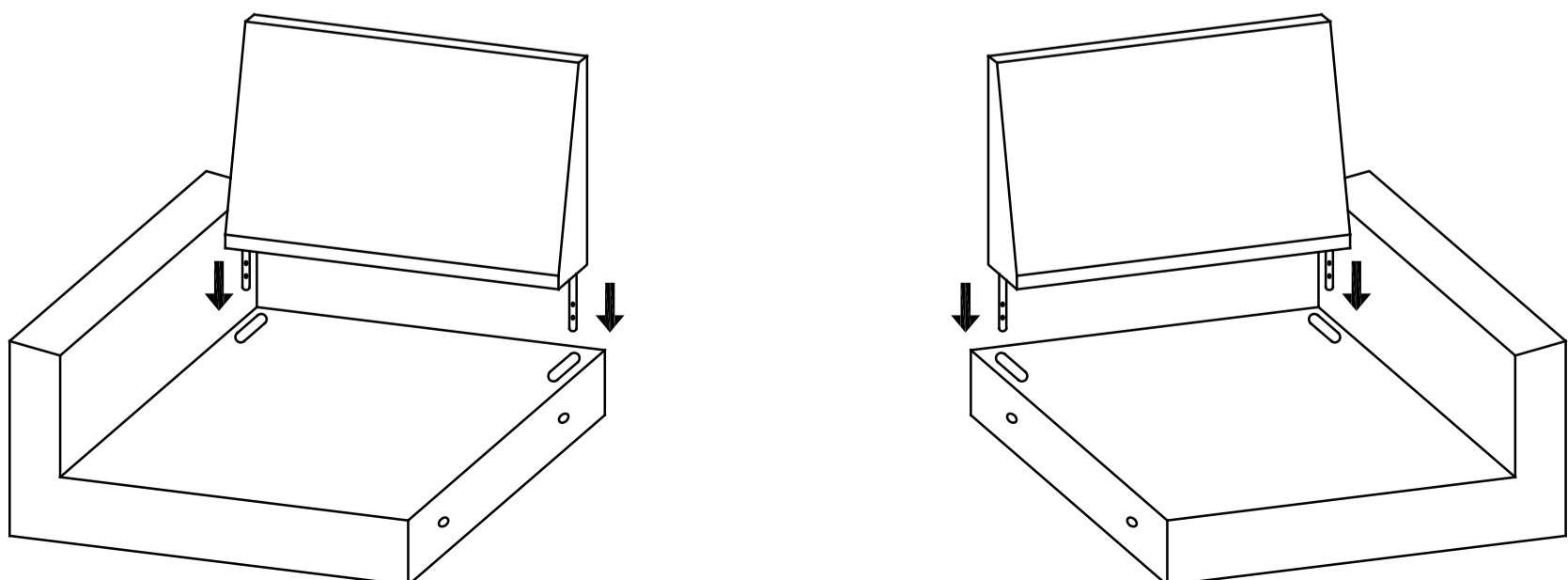

Step 4: Use 1 hand bolt per side to attach back to sofa end.

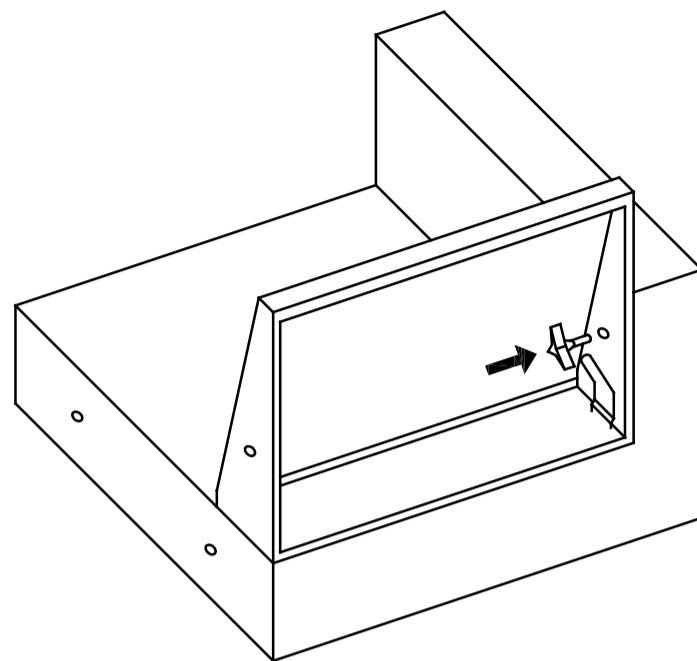
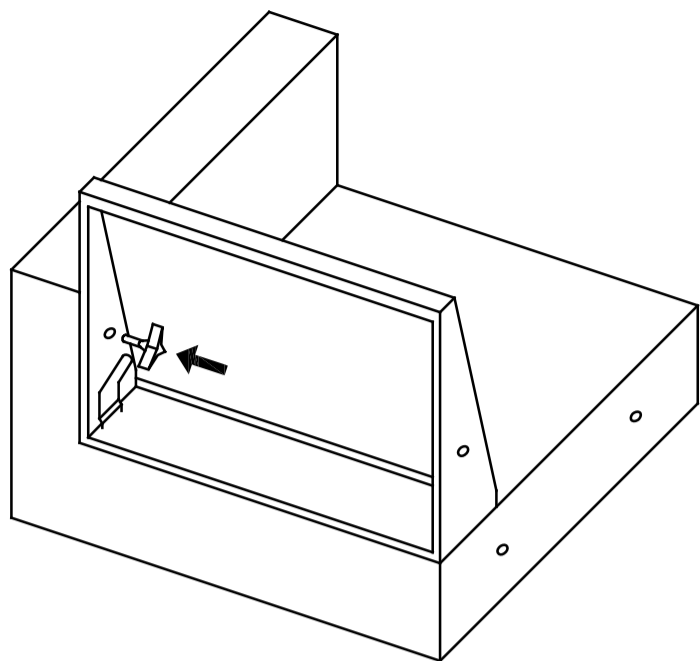

Step 5: Use 3 hand bolts to connect the two sofa ends together.

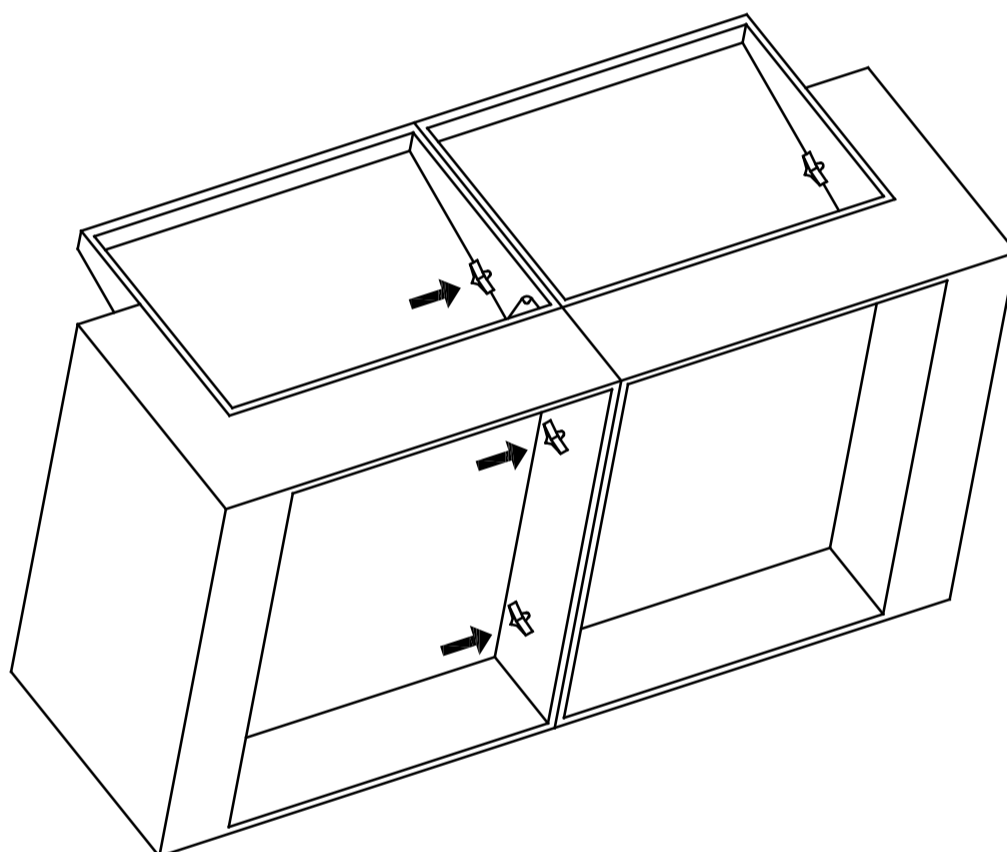

Step 6: Replace the back and bottom coverings and apply 5 legs to the bottom. Flip unit upright and place seat and back cushions. Please regulate and allow 48 hours for cushion to fully recover after unpacking.

