

## ASSEMBLY INSTRUCTION SHEET FOR D442-00/09

### IMPORTANT SAFETY NOTICE: READ CAREFULLY BEFORE BEGINNING ASSEMBLY!

- \* Always use proper tools.
- \* Follow the assembly steps in order. Do not skip any steps.
- \* Carefully review the list of parts. If parts are missing, contact the retailer from which you purchased the product to obtain any missing parts. DO NOT USE SUBSTITUTE PARTS.

- \* Periodically check to ensure that all connectors (bolts, screws, etc.) are tight.
- \* Keep the instructions for future reference.



NOTE: SIGNATURE DESIGN FURNITURE, LLC. DISCLAIMS ANY LIABILITY FOR DAMAGES OR INJURIES WHICH MAY OCCUR DUE TO FAILURE TO PROPERLY FOLLOW ASSEMBLY INSTRUCTIONS, PROPERLY ASSEMBLE THE PRODUCT, OR PROPERLY USE THE PRODUCT.

### CHECK TO SEE THAT THE FOLLOWING PARTS ARE IN THE HARDWARE PACK!

NO	DRAWING	Q'TY	DESCRIPTION	NO	DRAWING	Q'TY	DESCRIPTION
A		8	5/16"x64mm ALLEN BOLT	C		8	5/16" FLAT WASHER
B		8	5/16" LOCK WASHER	D		1	5mm ALLEN WRENCH

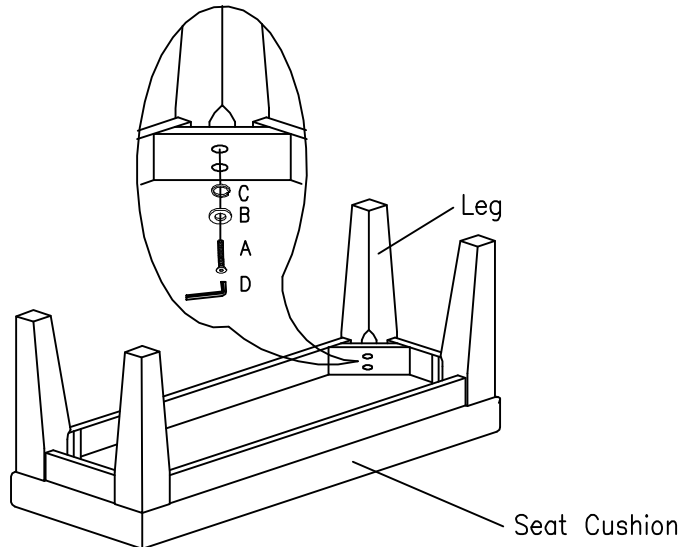

1. Place the seat cushion upside down onto a smooth and protective surface.
2. Attach a leg to one corner of the seat cushion by turning an Allen bolt A, lock washer B and flat washer C into each hole of the leg as shown.
3. Repeat for the remaining legs.
4. Tighten all bolts by using Allen wrench D.

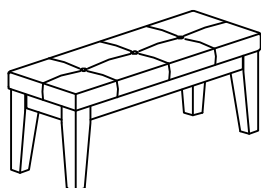

D442-00

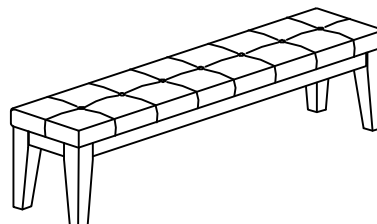

D442-09