

Item#	Qty	Description	MATERIAL
1	1	TOP ASSEMBLY	WOOD
2	2	DRAWER ASSEMBLY	WOOD/METAL
3	2	BEDLOCK	METAL
B22	4	FELT PAD	FABRIC
A60	2	LEFT CABINET GLIDE	METAL, PLASTIC
A61	2	RIGHT CABINET GLIDE	METAL, PLASTIC
F11	2	KNOB	METAL
H60	8	(H60) 10MM EURO SCREW	METAL

Dwg#: 36162			
Scale: 1:12		TOLERANCES ARE: METRIC: +.5 / -.5mm DECIMAL: 0 / -.005" FRACTIONAL: +0 / -1/32" (UNLESS OTHERWISE SPECIFIED)	
Date: 8/28/2025		Desc: Strg Footboard CS	
Rev.	Description	Date	Cad/Eng

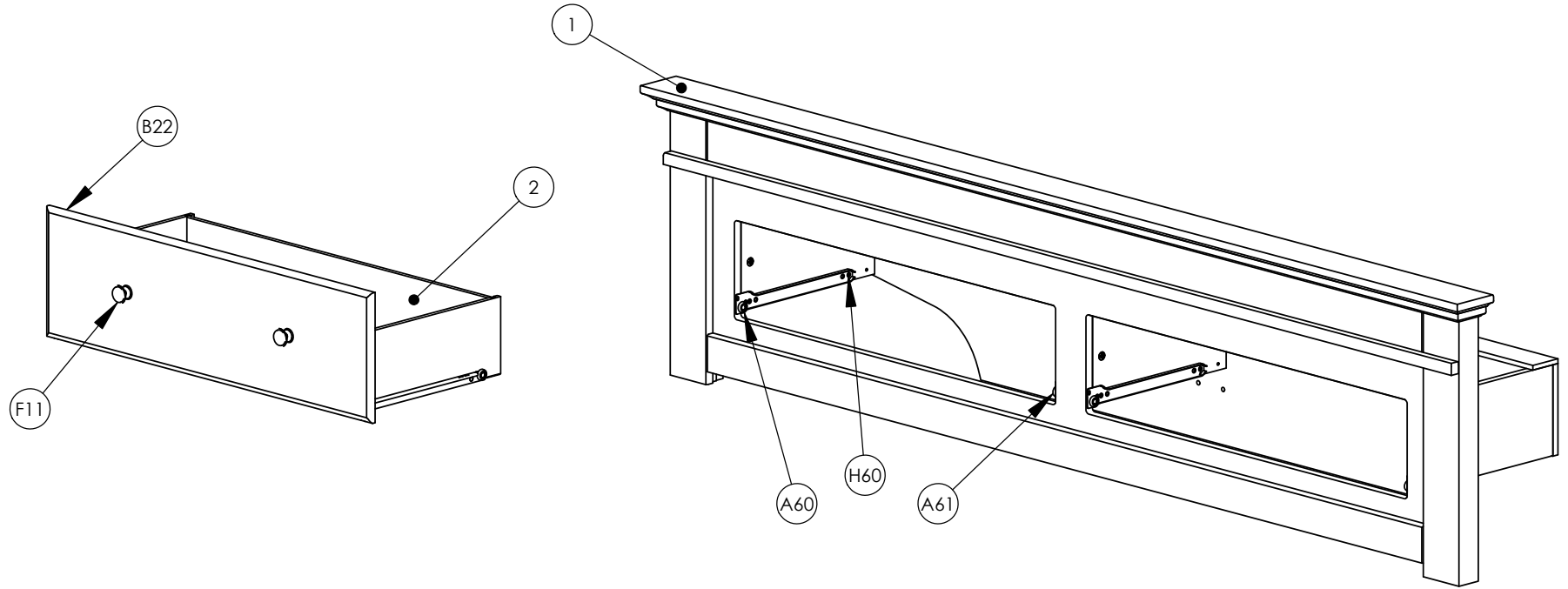

BACK VIEW

