

Item#	Qty	Description	MATERIAL
1	1	TOP ASSEMBLY	WOOD
2	1	DRAWER ASSEMBLY	WOOD/METAL
3	2	BEDLOCK	METAL
A60	1	LEFT CABINET GLIDE	METAL, PLASTIC
A61	1	RIGHT CABINET GLIDE	METAL, PLASTIC
B22	2	FELT PAD	FABRIC
F11	2	KNOB	METAL
H60	4	(H60) 10MM EURO SCREW	METAL

Dwg#: 36157			
Scale: 1:12	TOLERANCES ARE: METRIC: ..... +.5 / -.5mm DECIMAL: ..... 0 / -.005" FRACTIONAL: ..... +0 / -1/32" (UNLESS OTHERWISE SPECIFIED)		
Date: 8/27/2025	Desc: Strg Footboard CS		
Rev.	Description	Date	Cad/Eng

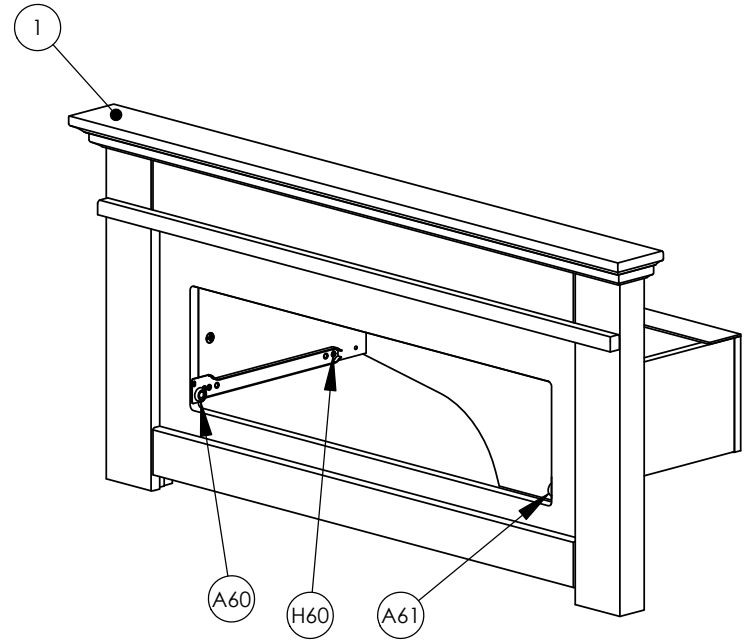

BACK VIEW

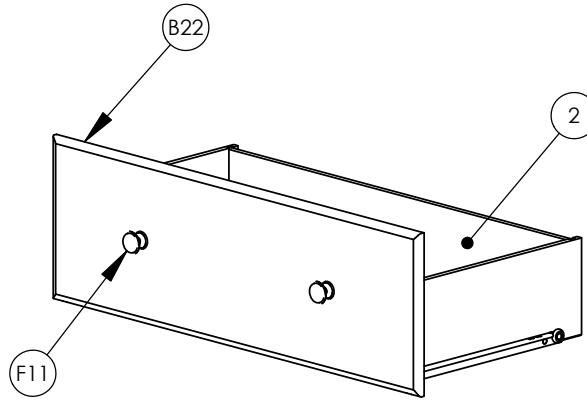